

STELLAR Series

Next gen LED High-Bay Luminaire



CREE LIGHTING



SAY YES TO 24/7 SAVINGS. Stellar, Industrial lighting like never before.

Superb Light Quality and Performance Matched to Your Application

The Stellar High-Bay luminaire offers dominant performance in a wide variety of applications. Including Lumen packages from 13000 to 31000 lumens. 80 CRI is available as a standard together with specifically engineered lenses that provide comfortable controlled lighting for the target applications.

Tailored engineering and excellent light distribution

Stellar has been engineered with a compact, lightweight flat design. Four sizes complete the range, each of them optimized according to a specific Lumen package and performance. The fixture can be easily combined together with a dedicated reflector to change its appearance or shape the light distribution concealing the LED Sources from direct view.

Engineered for a Lifetime of Maximum Savings and Performance

The Stellar Series offers industrial grade durability and virtually maintenance free operation for an extended lifetime. Stocking replacement lamps and ballasts are a thing of the past, along with zero warm up, restrike times and hazardous bulb disposals.

OUTSTANDING PERFORMANCE WITH THE UTMOST FLEXIBILITY.

At Cree Lighting, we're continuing to improve high-bay LED performance with the introduction of our StellarSeries, delivering extreme energy savings and exceptional lumen maintenance without sacrificing what's important - better light and near maintenance-free operation. With multiple lumen, CRI and CCT packages; reflectors and lenses, Stellar makes selecting the ideal solution for your application quick and easy - whether it's industrial, grocery, gymnasium, retail, manufacturing or warehouse. Lightweight construction and universal mounting make installations near effortless, getting you back to what's important.

INDUSTRIAL-GRADE RELIABILITY

The higher the mounting height, the higher the stakes. Stellar has been designed with extreme care in order to guarantee the utmost reliability and longlasting performance. LEDs are circularly arranged on the heatsink to maximize an high efficient thermal conduction. Integrated lenses are moulded with stabilized Polycarbonate anti UV and have been calibrated in their thickness to provide IK08. Robust 6kV surge protection and external robust Flicker free driver make the Stellar Series a fixture you can count on.

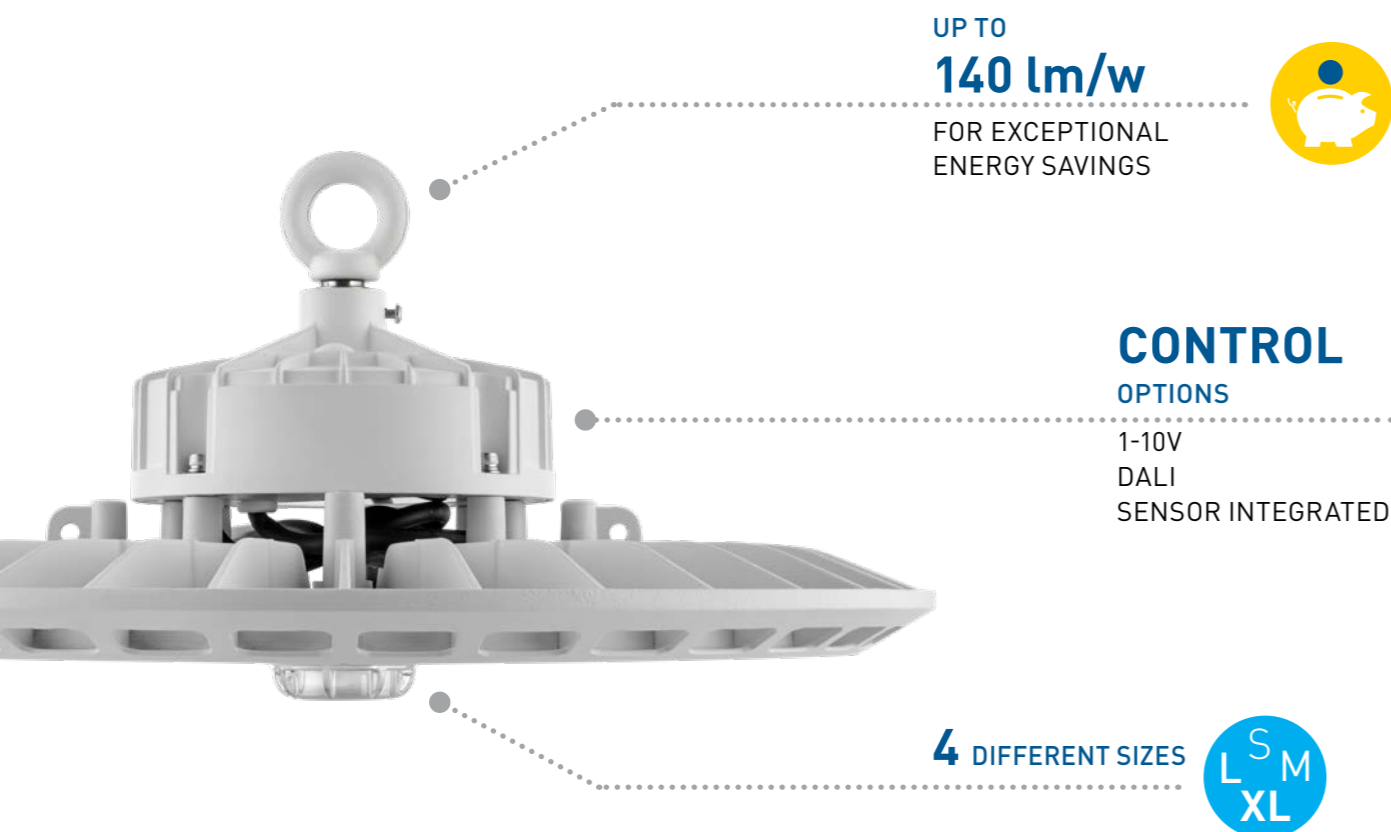

MULTIPLE LENS OPTIONS COVER ALL ANGLES.

NO APPLICATION IS OUT OF REACH

The versatility of the design makes it adaptable to any application option and to any ceiling. With a range of 4 different sizes and different mounting options, Stellar is the best choice to design an entire space: suspended, recessed, wall mounted and Uplight Option / downlight for suspension and wall mounting.

INSTALLER FRIENDLY FEATURES

MOUNTING

Eyebolt, Hook, Universal U Bracket, Steel chain and safety rope

OPERATIVE TEMPERATURE

-35° C up to +45° C

INITIAL COLOUR CONSISTENCY

5 steps MacAdam

POWER FACTOR

Up to > 0.95 at full load

CONTROL OPTIONS

Dimming 1-10V;
Dimming with sensor; DALI

APPLICATIONS

Industrial, sport, warehouse, retail and grocery spaces

LIMITED WARRANTY

5 Yrs (extended warranty available)

INTEGRATED PRECISION OPTICS AVAILABLE IN THREE DISTRIBUTIONS

60°; 90°; 120°

60° INTENSIVE OPTIC

Ideal for Warehouse installation



90° RECTANGULAR OPTIC

Best results for Sport facilities

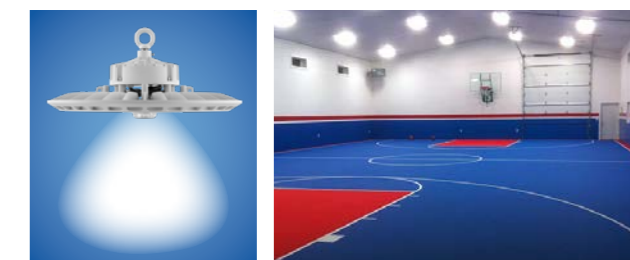

120° WIDE OPTIC

Optimized for Indoor Commercial applications



STELLAR Series

Next gen LED High-Bay Luminaire



CREE LIGHTING

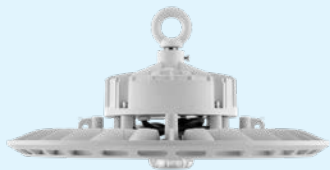

100W

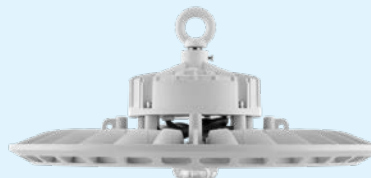

200W

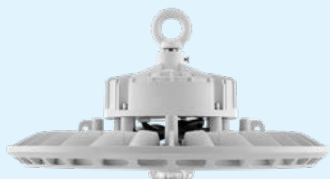

150W

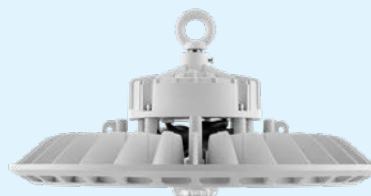

240W

FIELD INSTALLABLE OPTIONS SAVE TIME, MONEY AND SKUS

The STELLAR Series is designed to make selecting and configuring the right fixture for your space a snap. Right sized components and opt-in features remove the cost and weight of unneeded capacities. With a wide range of user-installable options and accessories, the Stellar Series means fewer fixture SKUs to inventory, making it flexible enough for distributor stock and flow.

- LENSES
- OCCUPANCY SENSORS
- STAINLESS STEEL CHAIN
- SAFETY ROPE
- ALUMINIUM REFLECTOR
- UNIVERSAL BRACKET
- REMOTE CONTROL
- HOOK COMPONENTS



PERFORMANCE SUMMARY

INITIAL DELIVERED LUMENS

13000 - 31000 lm

LUMEN PACKAGES

13L=100W; 20L=150W; 27L=200W; 31L=240W

EFFICACY

Up to 140lm/W

CRI/CCT

80 CRI / 3000K, 4000K, 5000K

IP/IK

IP65 / IK08

INPUT VOLTAGE

220-240V

LIMITED WARRANTY

5 yrs (Extended Warranty Available)

MOUNTING

Eyebolt, Hook, Universal U Bracket, Steel chain and safety rope

CONTROL

Dimming 1-10V;
Dimming with sensor; DALI