



Cree® OSQ-HO™ Series LED High Output Area/Flood Luminaire



Advanced
LIGHTING TECHNOLOGIES

CREE LIGHTING

TIMELESS DESIGN WITH THE TECHNOLOGY OF THE FUTURE

EXCEPTIONAL LIGHT QUALITY

The clean, modern housing of the OSQ Series improves your site aesthetics during the daytime, while the performance of our NanoOptic® Technology ensures improved, even illumination during the night.

LEADING – EDGE PERFORMANCE

Cree LED lighting offers efficient and reliable solution that optimize illumination while blending in with your architecture. Our uniform, shadow-free illumination also improves nighttime visibility, creating a safer environment for your employees and visitors.

THE FLEXIBILITY YOU NEED

Traditional luminaire technologies offer limited optical selections. With our patented NanoOptic® Technology, the choices keep coming. We have highly-efficient optics available in multiple distributions to provide new possibilities for highly-optimized target illumination performance and the flexibility you need to achieve the specific illumination requirements for each unique application.

LED High Output Area/Flood Luminaire

SEEKING BETTER LIGHT

At Cree, we're obsessed with going beyond the imagined possibilities of what light can do. The OSQ Series is the result of advanced LED technology and Cree's need to constantly improve the overall performance and value of our products.

PERFORMANCE SUMMARY

- **Full cut-off optics** (NanoOptic® Precision Delivery Grid™)
- **CCT:** 3000K, 4000K, 5700K, 5000K@CRI90 (CRI Standard min.70)
- **Initial Colour Consistency:** 4 steps MacAdam
- **IP Rating:** IP66
- **IK Rating:** IK08
- Die-cast aluminium body with lower copper content
- Tool-less entry, Removable tray
- Slim, low-profile design minimizes wind load requirements
- Integral, weathertight LED driver compartment and high performance heat sink integrated

MOUNTING OPTIONS & DIMENSIONS

DIRECT MOUNT

Weight: 35kg

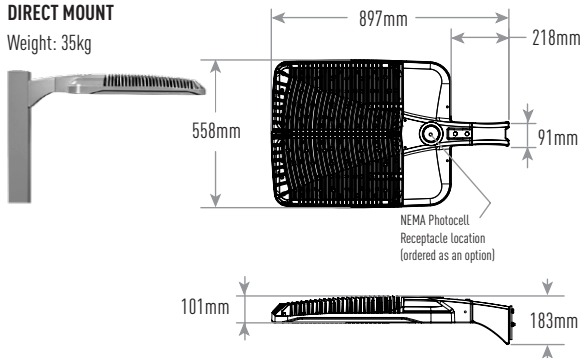

APPLICATIONS



Parking

Whether you're trying to attract business or simply want to create a safe and secure environment, well lit parking lots are extremely important. But better light can also offer significant savings. The OSQ High Output luminaire delivers dramatic improvement to both parking lots and pocketbooks.



Automotive

Attract customers with an outdoor showcase that leads to a better shopping experience. Available with Cree TrueWhite® Technology and utilizing our FrontlineOptic™, the OSQ™ High Output delivers exceptional color quality (90CRI) to the frontline – ensuring true-to-life paint colors are on full display.

Accessory Information

MOUNT (LUMINAIRE MUST BE ORDERED SEPARATELY)

OSQ-HO-DA* Direct Arm

BACKLIGHT SHIELD

OSQ-BLSMF Backlight Shield Front Facing Optics

OSQ-HO-BLSMR Backlight shield rotated optics

* Color options are: **WH** White **BK** Black **SV** Silver **BZ** Bronze