

# LR200™

200mm High Output Architectural LED Downlight



## Product Description

The LR200™ high output architectural LED downlight delivers up to 3000 lumens of exceptional 90+ CRI light while achieving over 74 lumens per watt. This breakthrough performance is achieved by combining the high efficacy and high-quality light of Cree TrueWhite® Technology. The LR200 is available in warm and cool color temperatures and features spec grade aesthetics with a polished lower reflector. It is designed to easily install in 190-210mm diameter ceiling openings, making the LR200 perfect for use as a CFL and metal halide downlight replacement in commercial new construction or retrofit applications.

## Performance Summary

Utilizes Cree TrueWhite® Technology
Active Color Management
<b>Delivered Light Output:</b> 2000, 3000* lumens
<b>Input Power:</b> 27, 40 watts
<b>CRI:</b> 90
<b>CCT:</b> 3000K, 4000K
<b>Input Voltage:</b> 220-240V
<b>Warranty:</b> 10 years
<b>Lifetime:</b> Designed to last 50,000 hours
<b>Dimming:</b> Dimmable to 5% with DALI and Analog 1-10V dimmers

LR200

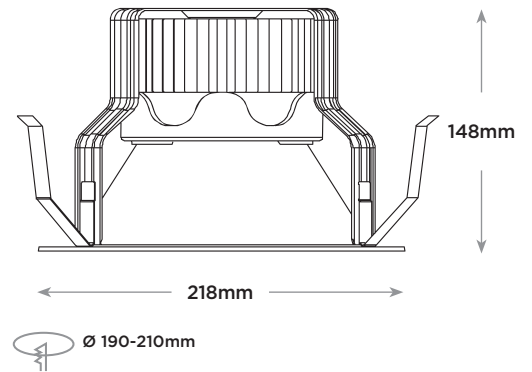

## Ordering Information

Example: LR200-2000L-40K-23-ADIM

LR200					
Product	Lumen Output	Color Temperature	Voltage	Control	Options
LR200	<b>2000L</b> 27W 2000 lumens - 74 LPW	<b>30K</b> 3000 Kelvin	<b>23</b> 220-240 Volt	<b>ADIM</b> 1-10V Dimming	<b>BLANK</b> CE/CB certified
	<b>3000L</b> 40W 3000 lumens - 75 LPW*	<b>40K</b> 4000 Kelvin		<b>DALI</b> Dimmable to 5%	<b>CP</b> CCC certified

\*Pending CCC certification.

# LR200™

200mm High Output Architectural LED Downlight

## Product Specifications

### CREE TRUEWHITE® TECHNOLOGY

A revolutionary way to generate high-quality white light, Cree TrueWhite® Technology mixes the light from the highest performing red and unsaturated yellow LEDs. This patented approach delivers an exclusive combination of 90+ CRI, beautiful light characteristics, and lifelong color consistency, all while maintaining high luminous efficacy—a true no compromise solution.

### CONSTRUCTION & MATERIALS

- Durable engineered polycarbonate housing and support cup protect LEDs and optical lens. Integral spring clips resist heat while providing retention for flush ceiling fit.
- Engineered polycarbonate remote gear box protects driver, power supply and terminal block.
- Thermal management system uses extruded aluminum heat sink to conduct heat away from LEDs and transfer it to the plenum space for optimal performance. LED junction temperatures stay below specified maximum when installed in non-insulated ceiling applications. Not for direct burial in insulation.
- One-piece engineered polycarbonate lower reflector with vacuum metalized finish redirects light while also conducting heat away from LEDs. It creates a comfortable visual transition from the lens to the ceiling plane.

### OPTICAL SYSTEM

- Unique combination of reflective and refractive optical components achieves a uniform, comfortable appearance while eliminating pixelation and color fringing. This ensures smooth light patterns are projected with no hot spots and minimal striations.
- Components work together to optimize distribution, balancing the delivery of high illuminance levels on horizontal surfaces with an ideal amount of light on walls and vertical surfaces. This increases the perception of spaciousness.
- Diffusing lens shields direct view of LEDs while lower reflector balances brightness of lens with the ceiling to create a low-glare high angle appearance.

### ELECTRICAL SYSTEM

- Remote high-efficiency driver and power supply.
- **Power Factor** > 0.9 nominal
- **Input Voltage:** 220-240V, 50/60Hz
- **Dimming:** Dimmable to 5% with DALI and Analog 1-10V dimmers.

### REGULATORY & VOLUNTARY QUALIFICATIONS

- CE/CB certified.
- CCC certified.

## Photometry

### LR200-2000L BASED ON LTL TEST #: 22891

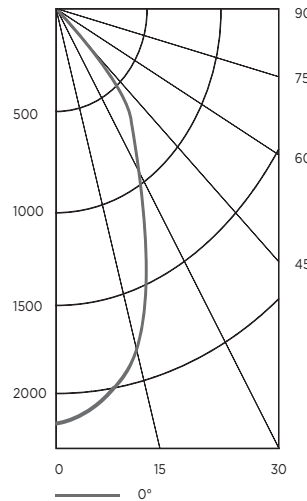

### Intensity (Candlepower) Summary

Angle	Mean CP
0°	2177
5°	2126
15°	1866
25°	1129
35°	733
45°	328
55°	55
65°	0
75°	0
85°	0
90°	0

### Zonal Lumen Summary

Zone	Lumens	% Fix
0-30	1237	62.0%
0-40	1689	84.0%
0-60	1999	99.0%
0-90	2000	100%

Reference CreeLighting.com/International for detailed photometric data.

## Installation

- Designed to easily install in 190-210mm diameter ceiling openings.
- Integral spring clips engage with ceiling to hold luminaire in place.
- Remote gear box contains a conduit installation plate and a sheathed wire installation plate.

NOTE: Reference CreeLighting.com/International for detailed installation instructions.

## Application Reference

Open Space					
Spacing (m)	Lumens	Wattage	LPW	w/m <sup>2</sup>	Average Lux
1.2 x 1.2	2000	27	74	18.00	1298
1.8 x 1.8				8.40	602
2.4 x 2.4				4.50	331
3.0 x 3.0				3.00	241

Ceiling Height = 4.5m, 80/50/20 Reflectances, 0.75m workplane.  
 LLF: 1.0 Initial. Open Space: 15m x 12m

Corridor					
Spacing (m)	Lumens	Wattage	LPW	w/m <sup>2</sup>	Average Lux
1.2m on Center	2000	27	74	15.00	439
1.8m on Center				10.20	297
2.4m on Center				7.20	215
3.0m on Center				6.00	177

Ceiling Height = 4.5m, 80/50/20 Reflectances, light levels on ground.  
 LLF: 1.0 Initial. Corridor: 1.5m Wide x 30m Long

© 2012 Cree, Inc. All rights reserved. For informational purposes only. Not a warranty or specification. See [www.cree.com/patents](http://www.cree.com/patents) for patents that cover these products. Cree®, the Cree logo, Cree TrueWhite®, TrueWhite®, and the Cree TrueWhite Technology logo are registered trademarks and LR150™ is a trademark of Cree, Inc.