

# LR150-2000L

150mm High Output Architectural LED Downlight



## Product Description

The LR150-2000L high output architectural LED downlight delivers 2000 lumens of exceptional 90+ CRI light while achieving over 64 lumens per watt. This breakthrough performance is achieved by combining the high efficacy and high-quality light of Cree TrueWhite<sup>®</sup> Technology. The LR150-2000L is available in warm and cool color temperatures and features spec grade aesthetics with a polished lower reflector. It is designed to easily install in 150-160mm diameter ceiling openings, making the LR150-2000L perfect for use as a CFL downlight replacement in commercial new construction or retrofit applications.

## Performance Summary

Utilizes Cree TrueWhite <sup>®</sup> Technology
Active Color Management
<b>Delivered Light Output:</b> 2000 lumens
<b>Input Power:</b> 31 watts
<b>CRI:</b> 90
<b>CCT:</b> 3000K, 4000K
<b>Input Voltage:</b> 220-240V
<b>Warranty:</b> 5 years*
<b>Lifetime:</b> Designed to last 50,000 hours
<b>Dimming:</b> Dimmable to 5% with DALI and Analog 1-10V dimmers*

LR150-2000L

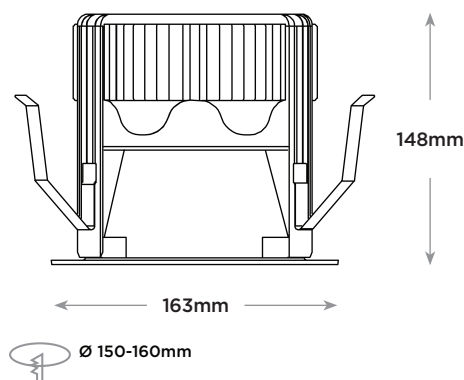
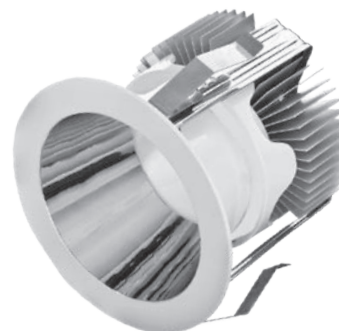

## Ordering Information (Limited inventory - Consult Factory for availability)

Example: LR150-2000L-40K-23-ADIM

Product	Lumen Output	Color Temperature	Voltage	Control	Options
LR150-2000L	2000L 31W 2000 lumens	30K 3000 Kelvin 40K 4000 Kelvin	23 220-240 Volt	ADIM 1-10V Dimming DALI Dimmable to 5%	BLANK CE/CB certified CP CCC certified

\* Reference [www.cree.com/lighting](http://www.cree.com/lighting) for recommended dimming control options.

† See [www.cree.com/lighting/products/warranty](http://www.cree.com/lighting/products/warranty) for warranty terms.

# LR150-2000L

150mm High Output Architectural LED Downlight



## Product Specifications

### CREE TRUEWHITE TECHNOLOGY

A revolutionary way to generate high-quality white light, Cree TrueWhite Technology mixes the light from the highest performing red and unsaturated yellow LEDs. This patented approach delivers an exclusive combination of 90+ CRI, beautiful light characteristics, and lifelong color consistency, all while maintaining high luminous efficacy—a true no compromise solution.

### CONSTRUCTION & MATERIALS

- Durable engineered polycarbonate housing and support cup protect LEDs and optical lens. Integral spring clips resist heat while providing retention for flush ceiling fit.
- Engineered polycarbonate remote gear box protects driver, power supply and terminal block.
- Thermal management system uses extruded aluminum heat sink to conduct heat away from LEDs and transfer it to the plenum space for optimal performance. LED junction temperatures stay below specified maximum when installed in non-insulated ceiling applications. Not for direct burial in insulation.
- One-piece engineered polycarbonate lower reflector with vacuum metalized finish redirects light while also conducting heat away from LEDs. It creates a comfortable visual transition from the lens to the ceiling plane.

### OPTICAL SYSTEM

- Unique combination of reflective and refractive optical components achieves a uniform, comfortable appearance while eliminating pixelation and color fringing. This ensures smooth light patterns are projected with no hot spots and minimal striations.
- Components work together to optimize distribution, balancing the delivery of high illuminance levels on horizontal surfaces with an ideal amount of light on walls and vertical surfaces. This increases the perception of spaciousness.
- Diffusing lens shields direct view of LEDs while lower reflector balances brightness of lens with the ceiling to create a low-glare high angle appearance.

### ELECTRICAL SYSTEM

- Remote, high-efficiency driver and power supply.
- **Power Factor** > 0.9 nominal
- **Input Voltage:** 220-240V, 50/60Hz
- **Dimming:** Dimmable to 5% with DALI and Analog 1-10V dimmers.

### REGULATORY & VOLUNTARY QUALIFICATIONS

- CE/CB certified.
- CCC certified.

## Photometry

### LR150-2000L BASED ON LTL TEST # 22897

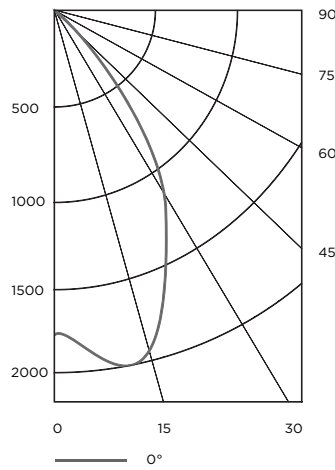

### Intensity (Candlepower) Summary

Angle	Mean CP
0°	1749
5°	1867
15°	1922
25°	1407
35°	738
45°	209
55°	15
65°	0
75°	0
85°	0
90°	0

### Zonal Lumen Summary

Zone	Lumens	% Fix
0-30	1351	68%
0-40	1809	90%
0-60	2000	100%
0-90	2000	100%

Reference [www.cree.com/lighting](http://www.cree.com/lighting) for detailed photometric data.

## Installation

- Designed to easily install in 150-160mm diameter ceiling opening.
- Integral spring clips engage with ceiling to hold luminaire in place.
- Remote gear box contains a conduit installation plate and a sheathed wire installation plate.

NOTE: Reference [www.cree.com/lighting](http://www.cree.com/lighting) for detailed installation instructions.

## Application Reference

Open Space					
Spacing (m)	Lumens	Wattage	LPW	w/m <sup>2</sup>	Average Lux
1.2 x 1.2	2000	31	64	20.67	1324
1.8 x 1.8				9.64	613
2.4 x 2.4				5.17	337
3.0 x 3.0				3.44	247

Ceiling Height = 4.5m, 80/50/20 Reflectances, 0.75m workplane.  
LLF: 1.0 Initial. Open Space: 15m x 12m

Corridor					
Spacing (m)	Lumens	Wattage	LPW	w/m <sup>2</sup>	Average Lux
1.2m on Center	2000	31	64	17.22	447
1.8m on Center				11.71	302
2.4m on Center				8.27	218
3.0m on Center				6.89	180

Ceiling Height = 4.5m, 80/50/20 Reflectances, light levels on ground.  
LLF: 1.0 Initial. Corridor: 1.5m Wide x 30m Long

© 2012 Cree, Inc. All rights reserved. For informational purposes only. Not a warranty or specification. See [www.cree.com/patents](http://www.cree.com/patents) for patents that cover these products. Cree®, the Cree logo, Cree TrueWhite®, TrueWhite®, and the Cree TrueWhite Technology logo are registered trademarks and LR150™ is a trademark of Cree, Inc.