

CR22™

595mm x 595mm Architectural LED Troffer



Product Description

The CR22™ architectural LED troffer delivers up to 3200 lumens of exceptional 90+ CRI light while achieving 90 lumens per watt. This breakthrough performance is achieved by combining the high efficacy and high-quality light of Cree TrueWhite® Technology with a unique thermal management approach. The CR22 is available in warm or cool color temperatures and has both 1-10V and DALI dimming options.

Its compact, lightweight design easily accommodates recessed, surface mount, or suspended installations, making the CR22 perfect for use in commercial new construction or retrofit applications.

Performance Summary

Utilizes Cree TrueWhite® Technology
Active Color Management
Room-Side Heat Sink
Efficacy: 90 LPW
Delivered Light Output: 2000, 3200 lumens
Input Power: 22, 35 watts
CRI: 90
Input Voltage: 3000K, 4000K
Tensione di ingresso: 220-240 VAC
Warranty: 10 anni
Lifetime: Designed to last 50,000 hours
Dimming: 1-10V or DALI Dimming to 5%†
Mounting: Recessed
Dimensions: L 595mm x W 595mm x H 120mm
Weight: 7 kg

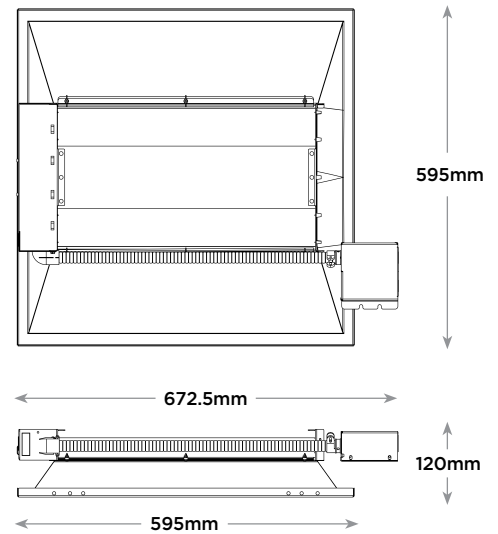

Ordering Information					
Example: CR22-20L-40K-23					
CR22					
Product	Lumen Output	Color Temperature	Control	Voltage	Options
CR22	20L 22W 2000 lumen - 100 L/W 32L 35W 3200 lumen - 90 L/W	30K 3000 Kelvin 40K 4000 Kelvin	No code Non-dimming ADIM 1-10V Dimming to 5% DALI* DALI Dimming to 5%	23 220-240V (Standard)	No code CE/CB certified

* Not available for codes CR22-20L

† Reference CreeLighting.com/International for recommended dimming control options

Product Specifications

CREE TRUEWHITE® TECHNOLOGY

A revolutionary way to generate high-quality white light, Cree TrueWhite® Technology mixes the light from the highest performing red and unsaturated yellow LEDs. This patented design creates a pleasing architectural aesthetic while conducting heat away from LEDs in a temperature controlled environment. This enables the LEDs to consistently run cooler, providing significant boosts to lifetime, efficacy, and color consistency, all while maintaining high luminous efficacy—a true no compromise solution.

ROOM-SIDE HEAT SINK

An innovative thermal management system designed to maximize cooling effectiveness by integrating a unique room-side heat sink into the diffusing lens. This breakthrough design creates a pleasing architectural aesthetic while conducting heat away from LEDs in a temperature controlled environment. This enables the LEDs to consistently run cooler, providing significant boosts to lifetime, efficacy, and color consistency.

LUMEN MAINTENANCE FACTORS

- Reference CreeLighting.com/International for detailed lumen maintenance factors

CONSTRUCTION & MATERIALS

- Durable 20-gauge steel housing with standard troffer access plate for electrical installation.
- Field replaceable light engine integrates LEDs, driver, power supply, thermal management, and optical mixing components.
- One-piece lower reflector finished with a textured high reflectance white polyester powder coating creates a comfortable visual transition from the lens to the ceiling plane
- Provided t-bar clips and holes for mounting support wires enable recessed or suspended installation
- Individual fixtures may be mounted end to end for a continuous row of illumination

NOTE: Reference CreeLighting.com/International for detailed instructions on field replacement of the light engine

OPTICAL SYSTEM

- Unique combination of reflective and refractive optical components achieves a uniform, comfortable appearance while eliminating pixelation and color fringing
- Components work together to optimize distribution, balancing the delivery of high illuminance levels on horizontal surfaces with an ideal amount of light on walls and vertical surfaces. This increases the perception of spaciousness
- Diffusing lens integrated with upward-facing LED strip eliminates direct view of LEDs while lower reflector balances brightness of lens with the ceiling to create a low-glare high angle appearance
- UGR < 19 Reflection factors 0,2/0,5/0,7

ELECTRICAL SYSTEM

- Integral, high-efficiency driver and power supply
- Power Factor = 0.9 nominal
- Input Power: Stays constant over life
- Input Voltage: 220-240V, 50/60Hz
- Dimming: Dimmable to 5% with Analog 1-10V or DALI control protocols. Reference CreeLighting.com/International for recommended dimming controls
- Temperature Rating: Designed to operate in temperatures 35 C and below room side and plenum side
- Total Harmonic Distortion: < 20%

REGULATORY & VOLUNTARY QUALIFICATIONS

- CE certified
- IP23

© 2016 Cree, Inc. and/or one of its subsidiaries. All rights reserved. For informational purposes only. Content is subject to change. Patent www.cree.com/patents. Cree®, the Cree logo, Cree TrueWhite®, and the Cree TrueWhite Technology logo are registered trademarks, and CR24™ is a trademark of Cree, Inc.

Rev. Date: 21 October 2016

Photometry

CR14-4000L BASED ON LTL REPORT TEST #: 24294

Fixture photometry has been conducted by a NVLAP accredited testing laboratory in accordance with IESNA LM-79-08. IESNA LM-79-08 specifies the entire luminaire as the source resulting in a fixture efficiency of 100%.

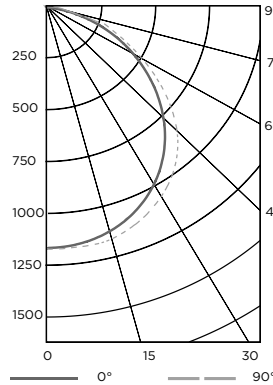

Average Luminance Table (cd/m ²)				
Vertical Angle	Angolo orizzontale			
		0°	45°	90°
	0°	3864	3864	3864
	45°	3575	3864	3972
	55°	3164	3656	3758
	65°	2498	3133	3347
	75°	1620	2348	2051
	85°	366	252	168

Coefficients of Utilization				
RCC %:	80			
RW %:	70	50	30	0
RCR: 0	3904	3904	3904	3904
1	3593	3447	3316	3199
2	3276	3018	2804	2624
3	2990	2655	2396	2189
4	2739	3254	2072	1857
5	2518	2103	1813	1599
6	2325	1893	1603	1395
7	2154	1715	1430	1231
8	2004	1564	1287	1097
9	1871	1434	1166	986
10	1754	1322	1064	892

Effective Floor Cavity Reflectance: 20%

Zonal Lumen Summary			
Zone	Lumens	% Lamp	Luminaire
0-30	1220	N/A	28,1%
0-40	1995	N/A	46,5%
0-60	3385	N/A	82,5%
0-90	3959	N/A	100%

Reference www.cree.com/lighting for detailed photometric data

Application Reference

Open Space					
Spacing (m)	Lumens	Wattage	L/W	w/m ²	Actual Lux
2.4 x 2.4	2200L	22W	90	3,76	305
	3200L	35W	90	5,91	480
2.4 x 3.0	2200L	22W	90	3,01	250
	3200L	35W	90	4,73	405
3.0 x 3.0	2200L	22W	90	2,37	215
	3200L	35W	90	3,76	340
3.0 x 3.6	2200L	22W	90	2,04	175
	3200L	35W	90	3,12	275

3m ceiling: 80/50/20 reflectances; 0.75m workplane, open room. LLF: 1.0 Initial Open Space: 15m x 12m x 3m