

Urban lighting

# ZOYA



### LUMINAIRE



- Die-cast aluminium body (EN 47100).
- Double layer polyester powder paint resistant to corrosion and salt spray fog.
- Silicone rubber gaskets.
- AISI 316 stainless steel external screws.
- Wiring on removable galvanized steel tray.
- Driver protected against voltage surges up to 4kV.
- Reflector made of anodized aluminium with non-iridescent specular finishing.
- PMMA lenses for LEDs.
- Shatterproof polycarbonate screen, UV-rays stabilized, V2 self-extinguishing.
- High quality LED sources characterized according to IES TM-30, with high color consistency <3SDCM and long useful life >60000 hours at L80.
- It complies with standards EN 60598-1 and EN 60598-2-3.

### INSTALLATION

- Post-top installation (Ø60mm reduction).
- Supplied with power cable ended (0.15m) by IP66 socket-plug connector with locking ring for cables of diameter 9-12mm.

Available versions with Casambi and other modern control systems, for more information see "Light controls" section.

**Available wired with Zhaga Book 18 or NEMA ANSI C136.41 (5-pin) and waterproof cover.**

| STANDARD PRODUCT |  | AVAILABLE OPTIONS  |  |
|------------------|--|--|--|
| Wiring           | ON/OFF (A)   | DALI (B), BIP (E)  |  |
| CCT              | 4000K (-840)   | 3000K (-830)   |  |
| Colour           |  21 |  12,  16 |  |



📍 Ville de Le Touquet-Paris-Plage - France

Urban lighting

# ZOYA

COMFORT





STANDARD COLOUR

 21

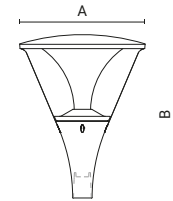
DIMENSIONS



| Code            | Optic   | Luminaire |        | CRI | CCT   | Class | Wiring | Power Supply     | A<br>mm | B<br>mm | C<br>mm |
|-----------------|---|-----------|--------|-----|-------|-------|--------|------------------|---------|---------|---------|
|                 |   | Watt      | Lumen  |     |       |       |        |                  |         |         |         |
| 0879000A-840-21 |  type VS | 40W       | 4350lm | 80  | 4000K | ☐     | ON/OFF | 220-240V 50/60Hz | 492     | 640     | -       |
| 0879001A-840-21 |  type VS | 56W       | 5800lm | 80  | 4000K | ☐     | ON/OFF | 220-240V 50/60Hz | 492     | 640     | -       |
| 0879002A-840-21 |  type VS | 81W       | 7700lm | 80  | 4000K | ☐     | ON/OFF | 220-240V 50/60Hz | 492     | 640     | -       |

 The **photo** represents the family product range. You can see the correct image of each product (code) on the website.

# OPAL





STANDARD COLOUR

 21

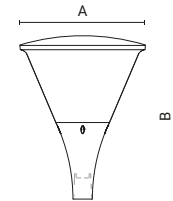
DIMENSIONS



| Code            | Optic   | Luminaire |        | CRI | CCT   | Class | Wiring | Power Supply     | A<br>mm | B<br>mm | C<br>mm |
|-----------------|---|-----------|--------|-----|-------|-------|--------|------------------|---------|---------|---------|
|                 |   | Watt      | Lumen  |     |       |       |        |                  |         |         |         |
| 0879003A-840-21 |  type VS | 40W       | 4500lm | 80  | 4000K | ☐     | ON/OFF | 220-240V 50/60Hz | 492     | 640     | -       |
| 0879004A-840-21 |  type VS | 56W       | 6050lm | 80  | 4000K | ☐     | ON/OFF | 220-240V 50/60Hz | 492     | 640     | -       |
| 0879005A-840-21 |  type VS | 81W       | 8100lm | 80  | 4000K | ☐     | ON/OFF | 220-240V 50/60Hz | 492     | 640     | -       |

 The **photo** represents the family product range. You can see the correct image of each product (code) on the website.

LED driver included.

**Available on request:**  
 versions with Future-Proof, see pag. 400.

# ZOYA

## SOFT LIGHT





### STANDARD COLOUR

● 21

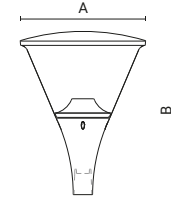

### DIMENSIONS



| Code            | Optic  | Luminaire |        | CRI | CCT   | Class | Wiring | Power Supply     | A<br>mm | B<br>mm | C<br>mm |
|-----------------|--|-----------|--------|-----|-------|-------|--------|------------------|---------|---------|---------|
|                 |  | Watt      | Lumen  |     |       |       |        |                  |         |         |         |
| 0879006A-840-21 |  type V | 42W       | 3500lm | 80  | 4000K | ☐     | ON/OFF | 220-240V 50/60Hz | 492     | 640     | -       |

The **photo** represents the family product range. You can see the correct image of each product (code) on the website.



For post top mounting, check all available solutions on page 402.

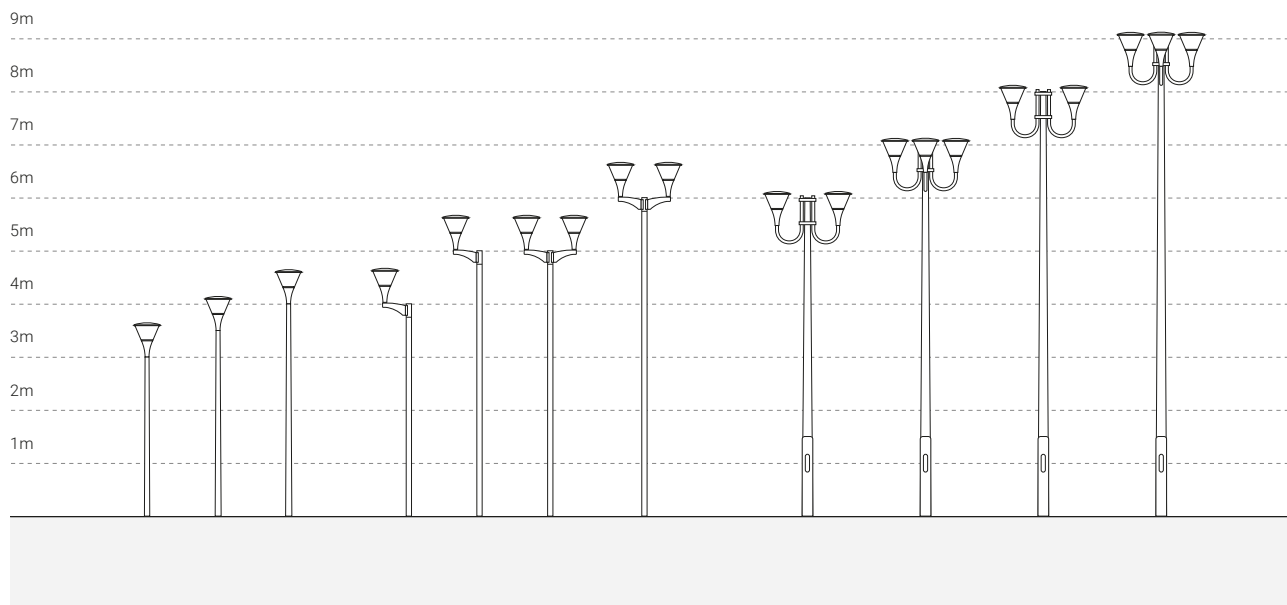

**LED driver included.**



**Available on request:**  
versions with Future-Proof, see pag. 400.

Urban lighting

# ZOYA

## ACCESSORIES

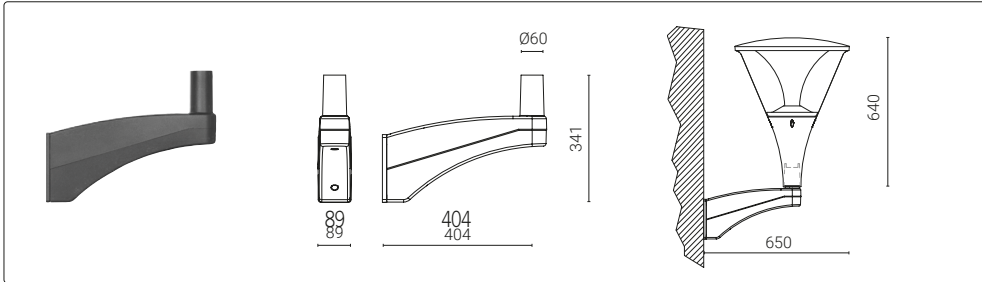

| Code               | Kg   |
|--------------------|------|
| <b>1099098X-21</b> | 2,50 |

Wall bracket.

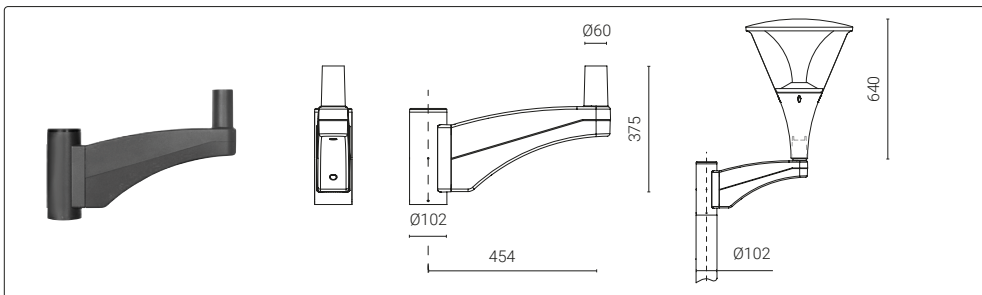

| Code               | Kg   |
|--------------------|------|
| <b>1099097X-21</b> | 3,50 |

Post-top mounting for single fixture for Ø 102 mm.

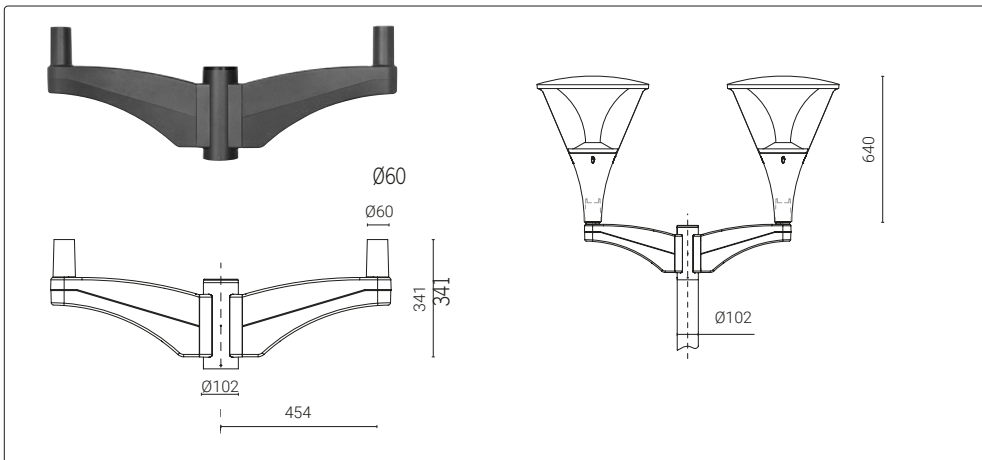

| Code               | Kg   |
|--------------------|------|
| <b>1099096X-21</b> | 6,00 |

Post-top mounting for double fixture for Ø 102 mm.



📍 Uppsala University, English Park - Uppsala, Sweden